

kaabo

USER MANUAL

Mantis X



Ningbo Kaabo Technology Co., Ltd.

Add: 3rd Floor, Building B3, Shanshan New Energy Base, NO. 238 Yunlin Middle Road, Haishu District, Ningbo Zhejiang, China

Tel: 0086-0574-88321118

Email: sales@kaabo.com

Web: www.kaabo.com



BEFORE YOU START

It is important to read through, understand, and adhere to all the instructions and safety warnings in this manual before charging and operating this scooter.

Upon receiving and opening your box, please inspect the contents for signs of damage or loose screws from transport. If something doesn't feel right, please take a few pictures and contact your place of purchase immediately.

Your scooter comes with a 180-day limited warranty against manufacturing defects. In case of any issues beyond this time frame, we will still help you but we may need to charge a fee for spare parts or repairs.

If you have purchased your scooter from a dealer other than kaabo.com, please contact them first in case of any issues. If you still need help or you have purchased directly from kaabo.com, please feel free to contact us with any questions or concerns.

Make sure you understand and adhere to local rules and regulations for riding electric scooters. Riding an electric scooter comes with inherent risks and hazards. To minimize risk of falling or being injured, make sure you understand how to safely operate and control this scooter.

Always use good judgement, common sense, and protective gear.

TABLE OF CONTENTS

GENERAL SAFETY WARNINGS	1
MANTIS OVERVIEW	2
What's in the Box	2
Technical Specifications	2
Safety Instruction	3
Key Components	4
CHARGING AND BATTERY SAFETY	5
Charging the Mantis	5
Battery Maintenance	5
Battery Disposal	5
Charging Warnings and Battery Safety Warnings	6
OPERATIONS	7
Assembling the Mantis	7
Folding your Scooter	8
DISPLAY & KEY SETTINGS	9
Turn Signal	9
KAABO Instrument key function	9
KAABO Instrument display	11
Controller Wiring Diagram	13
SCOOTER MAINTENANCE & TRANSPORT	14

GENERAL SAFETY WARNINGS

Always wear a helmet and protective safety equipment.

Wear closed shoes without heels and ensure your laces are tied.

Do not ride with more than one rider or exceed the weight limit of 120kg/265lbs in any other way.

Only use your scooter in line with its intended purpose.

Check your scooter for any loose parts or screws, flat tires, signs of damage or excessive wear before every ride. Stop operation immediately and contact your place of purchase if something does not feel right.

Start riding slowly to familiarize yourself with the operation of your scooter. Start in first gear and slowly try out the brakes. Always slow down when riding over bumps or on rough road conditions.

Keep the scooter away from children. It is not a toy. Riders must be age 16+ only.

Do not use your electric scooter in heavy rain, or on surfaces covered by more than ½ inch of water. Do not submerge the scooter in liquid or let any liquid near the battery or electrical components.

Do not lend your scooter to anybody unfamiliar with its operation. Ensure any new riders are familiar with these instructions and are wearing proper safety gear.

Once riding in public space, you are subject to the risks faced by all traffic participants just like when you are riding a bike.

- Other traffic participants may not obey traffic regulations or may ride carelessly.
- The faster you ride your scooter, the longer it will take you to stop.
- The scooter may slip on slippery surfaces leading to subsequent injuries to the rider. Pay special attention crossing train tracks and/or when it is wet.
- Always use caution, adapt your speed to road and traffic conditions and keep distance from other traffic participants.
- Watch out for pedestrians. Do not use your scooter in any way that could harm pedestrians.

Slow down when you are passing them to avoid accidents.

You must follow all local traffic rules and regulations.

01 MANTIS OVERVIEW

• What's in the Box:



Mantis Electric Scooter
(With detached handlebar)



Manual



2.0A charger



Tool

• Technical SPECIFICATIONS:

► SPECIFICATION-Mantis

<i>kaabo</i> ®	Mantis X	
Version Name	Mantis X Eco	Mantis X Plus
Configuration	48V 13Ah ★	48V 18.2Ah ★
color		
Battery Type	Li-Ion battery pack 18650	
Battery model	DMEGC26E	
Moter power	Brushless motors 500W (Separable version)	Brushless motors 500W *2 (Separable version)
Max.Speed	25km/h (50km/h)	
Max.Range	Around 55KM (75kgs load,25km/h flat road continous riding basis)	Around 75KM (75kgs load,25km/h flat road continous riding basis)
Climbing Angles	<20 °	<25 °
Max. load	120kg	
Charger	54.6V 2A GX16-3 1+2-	
Charging time (use 2A*1)	Around 6.5 hrs	Around 9 hrs
Shock Absorber	Front and rear damping&spring oil spring shock absorber (132mm)	Front and rear adjustable damping&spring oil spring shock absorber (132mm)
Brake	Disc brake +EABS (140mm)	
Light system	LED front light+LED deck light, Front and rear turn signals	
Controller	Kaabo Sine Wave controller	
Display	Kaabo Display	Kaabo KM03 Center Display (NFC function, USB charging)
Unfolding size	1247mm X 620mm X 1335mm	
Folding size	1247mm X 620mm X 585mm	
N.W.	25.2 KGS	29 KGS
G.W.	32.2 KGS	36 KGS
Tyres	10*3.0 inch (CST)	
Product material	Handle, frame, bar material 6061- t6 aluminum alloy and 6082- t6 aluminum forging; Cover PP; Shaft scm440;	

• SAFETY INSTRUCTION

► Tips

This Chapter is very important. Please read carefully and understand all the instruction. We will not be responsible for any property loss, casualties, accidents, legal disputes caused by violation of the safety instructions on chapter.



► Safety Instruction

1. Do not drive in rainy days.
2. Do not repair by yourself electric shocks can occur.
3. Please abide by the local road traffic law.
4. Do not acrobatics.
5. One scooter for one person only.
6. Better to wear safety protective equipment such as a helmet, gloves, elbow and knee pads when ride.
7. Please practice on open ground first, and then ride on the road.
8. Adjust to a suitable height to avoid injury.
9. Suggest charging six hours before the first time to ride the scooter.
10. Do not cut off the power when scooter is running.
11. Do not climb a step higher than 3cm to avoid turning over and possible injury.
12. Use and storage scooter temperature range is -5°C to 40°C.
13. If left a long time no use of the scooter charge it once every month to maintain the longevity if the battery.
14. Do not ride in puddle deeper than 5cm or avoid sprayed directly by water in case of motor or electrical faults.
15. Keep feet on pedal when the scooter is run table.

Devices are not intended for use at elevations greater than 2000 m above sea level.

Prolonged Exposure to UV Rays, Rain and the Elements May Damage the Enclosure Materials, Store Indoors When Not in Use
WARNING – Risk of Fire – No User Serviceable Parts
AVERTISSEMENT- Risque d'incendie et de choc électrique - Aucune des pièces ne peut être réparée par l'utilisateur



• Key Components

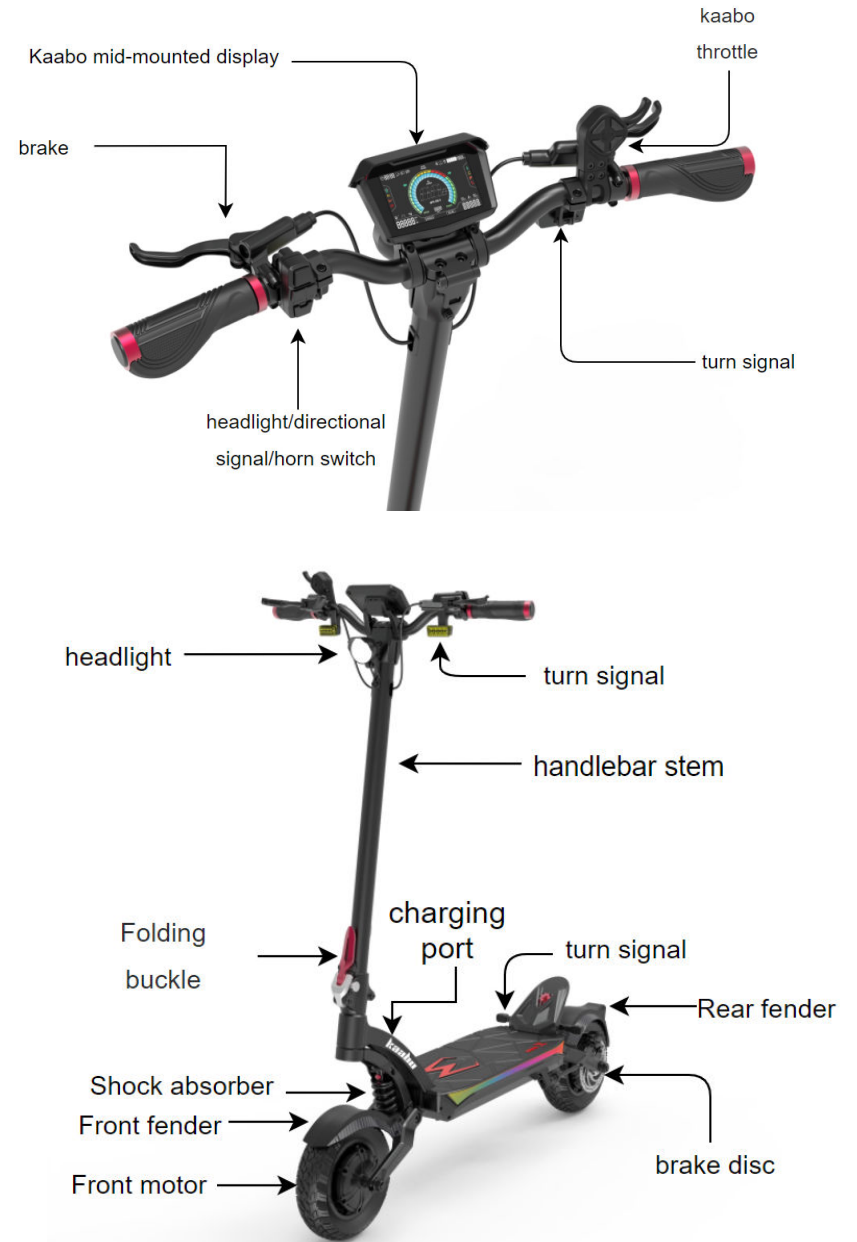

Charging the Mantis:

1. Turn your scooter off
2. Locate the charging port
3. Open the charging port cover
4. Connect the charger to the scooter's charging port
5. Plug in the charger to the wall power outlet

The LED on the charger will turn red while charging and turn green when the scooter is ready for use. Remove the charger and cover the plug. Charging time with the included 2A charger is 8-10 hours for the Mantis 18.2 Ah version.

Battery Maintenance

Battery dormancy: If the battery is not used for a long time (over 7 days), the battery automatically enters dormancy mode to protect the battery. The battery needs to be charged to activate it if enter dormancy mode.

We suggest charging your scooter after every use. This is not required but recommended.

A lithium-ion battery is a consumable device. Please replace with a new battery once capacity drops below 50% of what you experienced initially. Contact your place of purchase for a replacement.

Make sure the battery is charged and that the scooter is turned off before storing your scooter for extended periods at a time.

Store your scooter in a dry and cool place. Do not keep it outdoors or in outdoor sheds for extended periods of time, as excessive cold temperatures, heat, sunlight, rain, or other environmental conditions may impact safe operation and reduce the scooter's lifespan.

Charge your battery at minimum every 3 months to prevent it from running completely empty. Once the battery runs completely empty due to slow discharge while in storage, it may have to be replaced.

Batteries perform poorly at low temperatures. For instance, if the temperature is around 0°F (-18°C), battery capacity reduces by 50%. Capacity will restore to normal when temperatures rise.

Battery life and riding ranges will vary depending on usage, climate, conditions, rider weight, and/or riding style, proper care, and maintenance.

Battery Disposal

Do not dispose of your battery by way of land filling, incineration, or household trash.

We recommend disposing your battery through a local recycling program suitable for lithium-ion batteries. Contact your local waste management service for more information.

Mishandling of used batteries may do tremendous harm to the environment. You must abide by local laws and regulations to properly dispose of used batteries.

Charging Warnings and Battery Safety Warnings

- Use caution when using outlets to prevent electric shock.
- Do not leave the charger plugged in for extended period of times (>24 hours).
- Only charge your scooter in a safe, clean, and dry environment. Keep the charger and scooter away from inflammable materials as they may get hot.
- Only use the original battery packs and the original charger supplied with your electric scooter. Contact your place of purchase if you need a replacement. Use of other models or brands may not be safe.
- Do not touch any part of the USB charging prongs and keep them away from metal objects to prevent short circuiting which may result in battery damage or physical injuries, and/or death.
- Do not place the battery in direct contact with heat or near high temperatures. Do not expose the battery to direct sunlight. Do not leave the scooter in a car where the battery might get hot.
- Do not pierce the battery with sharp objects. Do not subject it to impact or force.
- Stop charging if the battery fails to recharge within the approximate charging time. This will prevent the battery from overheating, rupturing, or igniting.
- Do not charge the battery in temperatures below 32°F (0°C) or above 104°F (40°C) as this can hamper performance, result in breaking, overheating, rupturing, or igniting and could cause personal injury or property damage.
- Do not charge your scooter if the charging port on the scooter is damaged or wet. Do not charge if there is excessive heat, odor or leakage coming from the battery or it looks abnormal in any way.
- If the battery leaks and you accidentally get in touch with the liquid, rinse immediately and thoroughly with water and then seek medical care.
- Never attempt to disassemble, modify, perform repairs or maintenance on the battery. You run the risk of damaging the protective and safety components that prevent incidents, personal injury or property damage.
- Mishandling or misuse of the battery can result in lower performance, shorter lifespan, rupturing, igniting, or other incidents and could increase the risk of serious personal injury.
- Do not discharge the battery using any other product than the scooter it comes with. Doing so could result in damage to the other product or the battery, and reduced lifespan of your scooter. The battery could overheat, rupture, or ignite and cause personal injury or property damage.

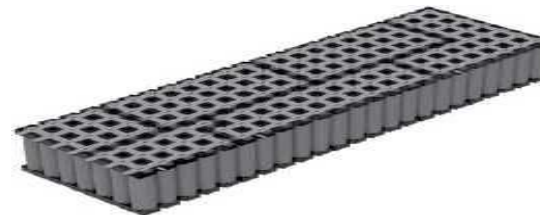

♦ Assembling the Mantis



Before driving, please make sure the quick release was locked, this is very important.

► Open



Step1:
Lift and straighten the handlebar stem.

Step2:

Open the protective pin to hold the folding wrench and then lock the protective pin.



Step3:
Finished

♦ Folding your Scooter

► Fold

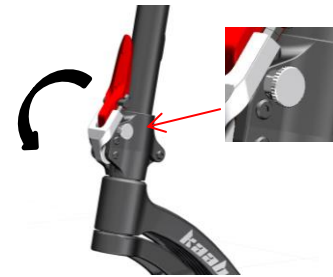

Step1:

Open the protection Pull off protection pin and rotate it to open status. Open the folding wrench

Step2:

Turn down the folding wrench and folding hook automatically away from cross pin. Put down the fold rod and snap the folding hook in position.



Step3:
Finished.

04 DISPLAY & KEY SETTINGS

Turn Signal



The switch has the following functions: light, turn signal, and horn button. When the light button is pressed, the front and rear deck light will turn on. When the turn signal button is pressed, the front and rear light will turn on and flash. When the horn button is pressed, the horn will sound. When multiple buttons are pressed, the priority for the function from highest to lowest is turn signal, brake, and then light.

KAABO Instrument key function

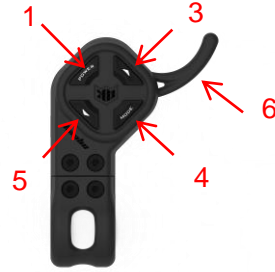

1: Power key 2: NFC Induction region 3: Upper key 4: Function key 5: Down key 6: Acceleration rod

Instructions for use:

1: Press the power button for 2 seconds to start the instrument.



2: After the meter is turned on, When the page shows NFC unlock screen, you need to put the NFC card into the NFC induction area of the instrument to unlock.

3: After the display is unlocked, you can adjust the gear with the up/down keys to suit your riding needs. There are 1-5 gears to choose from, 5 of which are maximum gear speeds.

4: Accelerator: Pull to accelerate. The stronger you pull, the faster it accelerates. The scooter is delivered in

“Non-Zero Start” setting (Kick-And-Go is ON), i.e. the accelerator only works if the scooter is already in motion.

5: After the meter is unlocked, tap the MODE key to check the contents



Do not wait to change until battery is fully running out. Change the scooter timely when there is only one rectangle or two left to avoid damage of battery.

6: After powering on the power supply and unlocking the NFC, hold down the MODE key within 10 seconds to enter the setting

MODE	description
UNT	System unit(default locking is not adjustable)
BLG	Instrument backlight Settings,1 gear,2 gear,3 gear can be selected,3 gear for the brightestbacklight mode
SLP	The automatic OFF time of scooter instrument,in minutes,is 0,5,10,10,20,30 minutes.After thesetting is complete,the scooter will automatically OFF within the set time without any operation
ESP	Electronic Stability Program 0=off 1=on (Only available if have this function)
S	Sport mode 0=off 1=on (Only available if have this function)
DSP	Instrument software version number,lock
PSd	Password set (default=1500)
TP	Theft Protection 0=off 1=on (Only available if have this function)
SET	Advanced Settings (password=1500)
RST	Reset system (Y=yes n=no)
Advanced Settings	
P1	Motor wheel diameter set,Set according to the actual wheel diameter,The general value is8-12,please do not change
P2	Speed limit as % of top speed,i.e.100=no speed limit.
P3	Motor magnetic pole setting.Default is 20 or 30.Do not change.
P4	E-ABS,1=EABS ON 0=E-ABS OFF
P5	EBS, There are five gear 1-5 1=weakest, 5 = strongest
P6	Start setting,1=non-zero start(Kick-and-Go), if the scooter is not moving,the accelerator will not work;0=Startimmediately(note when using)
P7	Fixed speed cruise setting,0 is no fixed speed cruise,1 is automatic fixed speed cruise
P8	System voltage,48V60V72V,default 48V please do not change
P9	Undervoltage value,38V48V58V default lock 38V please do not change
P10	Starting mode,0 is hard start,a total of 5 levels can be selected,1 is the soft start,4 is the softest start (Only available if have this function)
P11	Driving mode,There are three modes: 0, 1 and 2, The drive mode can be manually adjusted in 0 mode, 1 is the default single-drive, 2 is the default dual-drive, The default mode is 2.Do not manually modify the parameters.

Advanced Settings:

When the instrument has just been started and unlocked, long press M key for 2-3 seconds to enter the setting, You can select SET to enter P setting by pressing the up and down buttons of the instrument, select SEL and enter the password 1500 for P setting. Press the up/down key to select the corresponding P option, After setting, and long press the M key to return.

Cruise Control System:

When the P7 is set to 1, maintaining a constant speed for about 3-5 seconds during acceleration will activate automatic cruise,

The cruise can be cancelled by braking when driving on Cruise Control

KAABO Instrument Display

The Mantis scooter is equipped with the following display:

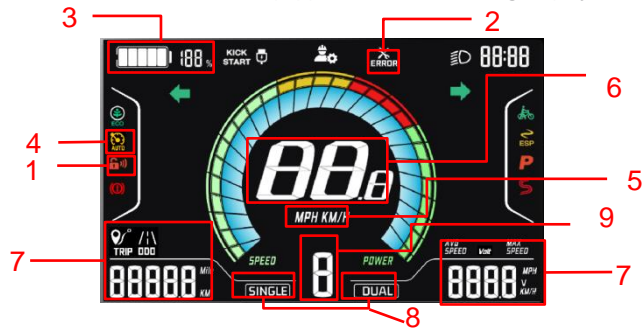

- 1: Indicates the NFC generation unlock mark
- 2: Indicates a fault
- 3: Electric quantity
- 4: Cruising mark
- 5: Unit of velocity
- 6: Speed display
- 7: Subtotal mileage, riding time, total mileage and voltage display
- 8: Single/Dual drive display
- 9: Gear display

Boot screen -NFC unlock:

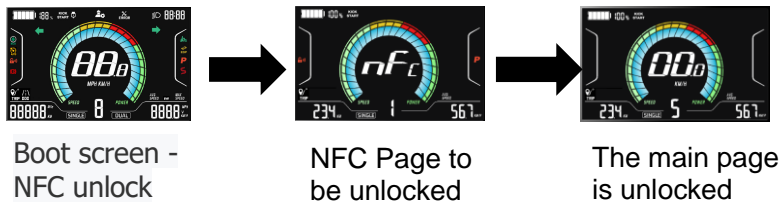

The startup interface will be displayed when the device is powered on. After the communication connection is established, the instrument will enter the NFC page to be unlocked. After swiping the card, the instrument will enter the home page. The meter does the actual display with the information obtained from the controller communication.

Display NFC learning card

After turning on the display and entering the main page of the instrument, press and hold the keys at the same time, the display enters the learning page, and then press the key briefly, the on the left side of the page flashes and place the card in the card-swiping area for about 3 seconds. After successfully learning the card, the on the left stops flashing and returns to steady light, indicating that writing the card is completed, Long press the key to exit card writing.

SCOOTER MAINTENANCE & TRANSPORT

Never perform maintenance on this product while the unit is powered on or charging. Always power off before performing maintenance. **Do not attempt to perform repairs or modify the scooter but contact your place of purchase or refer to a professional repair facility.**

Clean stains on your scooter's body with a damp cloth. Do not use alcohol, gasoline, kerosene, or other corrosive and volatile chemicals. Do not wash with high pressure cleaners. Make sure the scooter is turned off and unplugged during cleaning and ensure no moisture enters the charging port.

When transporting your scooter, please take into account that it contains lithium-ion batteries that are considered a hazardous material.

Always exercise caution and follow applicable rules and regulations when transporting your scooter. It is very likely that you will not be allowed to take your scooter and battery on an airplane.



NOTE: The screws in the 1.2.3 position shown in the figure, in order to prevent metal fatigue accidents, please replace these 5pcs screws after each year or reach 5,000 kilometers. Please check and maintain every three months at the nearest after-sale maintenance store.

NOTE: INFORMATION, SPECIFICATIONS, WARNINGS AND ALL OTHER DETAILS INCLUDED IN THIS MANUAL ARE SUBJECT TO CHANGE AT ANY TIME, WITHOUT PRIOR WRITING. INQUIRE WITH THE VENDOR'S AFTER-SALES DEPARTMENT FOR MORE INFORMATION.

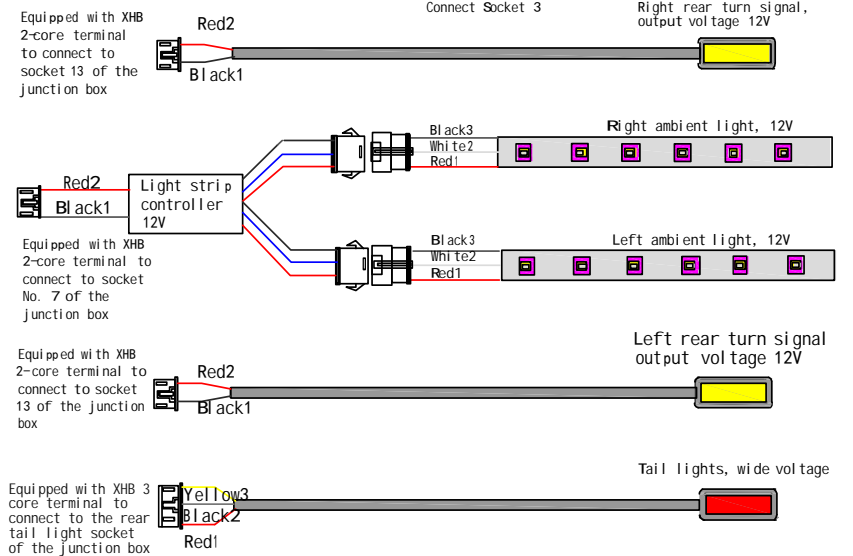
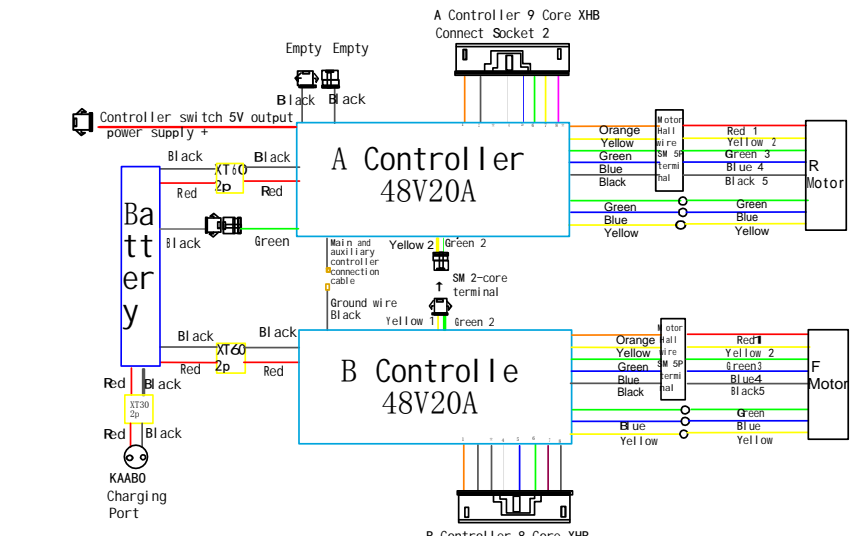
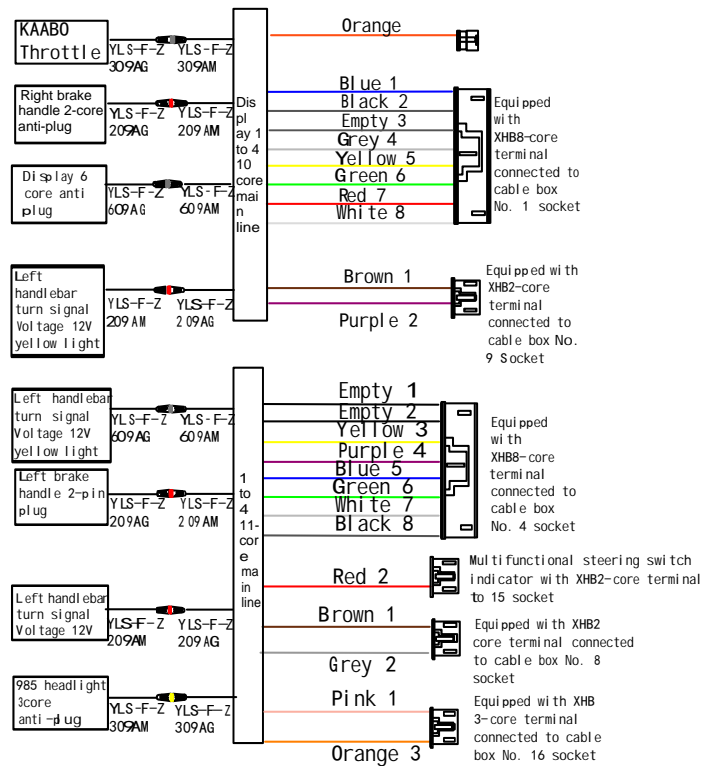
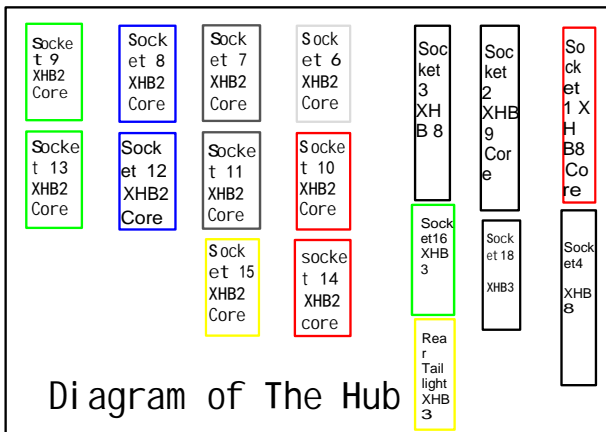

Wiring requirements:

- A: The internal circuit plug-in needs to be fixed with glue.
- B: Taboos for internal wiring (the unacceptable methods are as follows)
 - 1: The line is not effectively fixed (flying lines)
 - 2: The line is tightly welded for single fixation
 - 3: The line may come into contact with a sharp place if the line passes through a sharp place the sharp place needs to be wrapped to prevent the line from being cut and causing a short circuit
 - 4: Other incorrect wiring methods that may lead to reverse wiring, incorrect terminal insertion, short circuit, and incorrect insertion.

